

FILE

Union Special®

LEWIS • COLUMBIA

INDUSTRIAL
SEWING
MACHINES

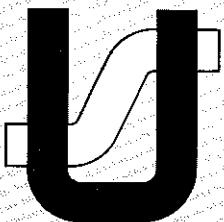

FINEST QUALITY

PROPERTY OF
DEVELOPMENT/CATALOG DEPT.
Please return to the Catalog Dept.
Date received to file: OCT 02 1992

**STYLE
39500MK**

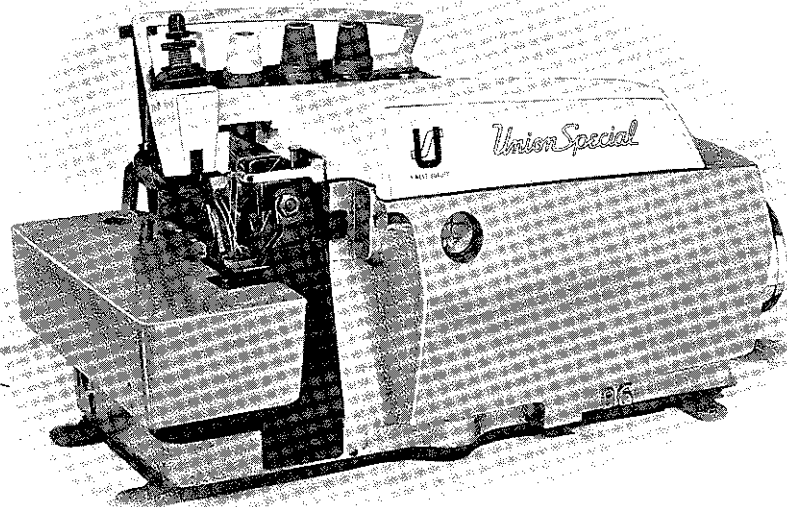

CLASS 39500

**HI-STYLED HIGH SPEED
TWO NEEDLE FOUR THREAD
THUMBSCREW ADJUSTED
DIFFERENTIAL FEED MACHINES**

**CATALOG
No.
103MK**

Union Special **MACHINE COMPANY**

CHICAGO

Catalog No. 103 MK
(Supplement to Catalog No. 103 FS)

INSTRUCTIONS
FOR
ADJUSTING AND OPERATING

LIST OF PARTS

CLASS 39500

Style 39500 MK

First Edition

Copyright 1971
by
Union Special Machine Co.
Rights Reserved in All Countries

Union Special
MACHINE COMPANY
INDUSTRIAL SEWING MACHINES
CHICAGO

Printed in U. S. A.

October, 1971

IDENTIFICATION OF MACHINE

Each Union Special machine is identified by a Style number on a name plate on the machine. Style numbers are classified as standard and special. Standard Style numbers have one or more letters suffixed, but never contain the letter "Z". Example: "Style 39500 MK". Special Style numbers contain the letter "Z". When only minor changes are made in a standard machine, a "Z" is suffixed to the standard Style number. Example: "Style 39500 MKZ".

Styles of machines similar in construction are grouped under a Class number which differs from the Style number in that it contains no letters. Example: "Class 39500".

APPLICATION OF CATALOG

This catalog is a supplement to Catalog No. 103 FS and should be used in conjunction therewith. Only those parts used on Style 39500 MK, but not on Style 39500 GD are illustrated and listed at the back of this catalog. On the page opposite the illustration will be found a listing of the parts, with their part numbers, description and the number of pieces required. Numbers in the first column are reference numbers only, and merely indicate the position of that part in the illustration. Reference numbers should never be used in ordering parts. Always use the part number listed in the second column.

This catalog applies specifically to the standard Style of machine as listed herein. It can also be applied with discretion to some Special Styles of machines in Class 39500. References to directions, such as right, left, front, back, etc., are given from the operator's position while seated at the machine. Operating direction of handwheel is away from operator.

STYLE OF MACHINE

Hi-Styled High Speed, Two Curved Blade Needles, Two Loopers, Four Thread Overseaming Machines, Upper Looper Thread is Caught by Both Needles. Differential Feed, Trimming Mechanism with Spring Pressed Lower Knife, Automatic Lubricating System.

39500 MK Medium to heavy duty machine for seaming operations on coat linings, pockets, bathing suits, house dresses, children's wear, ladies undergarments, and similar garments of medium to heavy weight woven and knitted materials of cotton, wool, silk and synthetics. Thumbscrew adjustable feed which allows either reverse or forward differential feeding. Seam specification 514-SSa-1. Standard seam width approximately 17/64 inch from left needle. Stitch range 6-20 per inch. Cam adjusted main and differential feeds. Maximum recommended speed 6000 R. P. M.

OILING

CAUTION! Oil was drained from machine when shipped, so reservoir must be filled before beginning to operate. Oil capacity of Class 39500 is six ounces. A straight mineral oil of a Saybolt viscosity of 90 to 125 seconds at 100° Fahrenheit should be used.

OILING (Continued)

Machine is filled with oil at spring cap in top cover. Oil level is checked at sight gauge on front of machine. Red bulb on oil level indicator should show between gauge lines when machine is stationary.

Machine is automatically lubricated. No oiling is necessary, other than keeping main reservoir filled. Check oil daily before morning start; add oil as required.

The oil drain plug screw is located at back of machine near bottom edge of base. It is a magnetic screw designed to accumulate possible foreign materials which may have entered the crank case. It should be removed and cleaned periodically.

NEEDLES

Each Union Special needle has both type and size number. The type number denotes the kind of shank, point, length, groove, finish and other details. The size number, stamped on the needle shank, denotes largest diameter of blade, measured in thousandths of an inch, midway between shank and eye. Collectively, type and size number represent the complete symbol which is given on the label of all needles packaged and sold by Union Special.

Class 39500 machines use a curved blade needle. The standard recommended needle for Style 39500 MK is Type 154 GAS. Below is the description and sizes available of the recommended needle.

<u>Type No.</u>	<u>Description and Sizes</u>
154 GAS	Round shank, round point, curved blade, standard length, single groove, struck groove, spotted, chromium plated and is available in sizes 022, 025, 027, 029, 032, 036, 040, 044, 049, 054, 060.

To have needle orders promptly and accurately filled, an empty package, a sample needle, or the type and size number should be forwarded. Use description on label. A complete order would read: "1000 Needles, Type 154 GAS, Size 036".

Selection of proper needle size is determined by size of thread used. Thread should pass freely through needle eye in order to produce a good stitch formation.

Success in the operation of Union Special machines can be secured only by use of needles packaged under our brand name, *Union Special*, which is backed by a reputation for producing highest quality needles in materials and workmanship for more than three-quarters of a century.

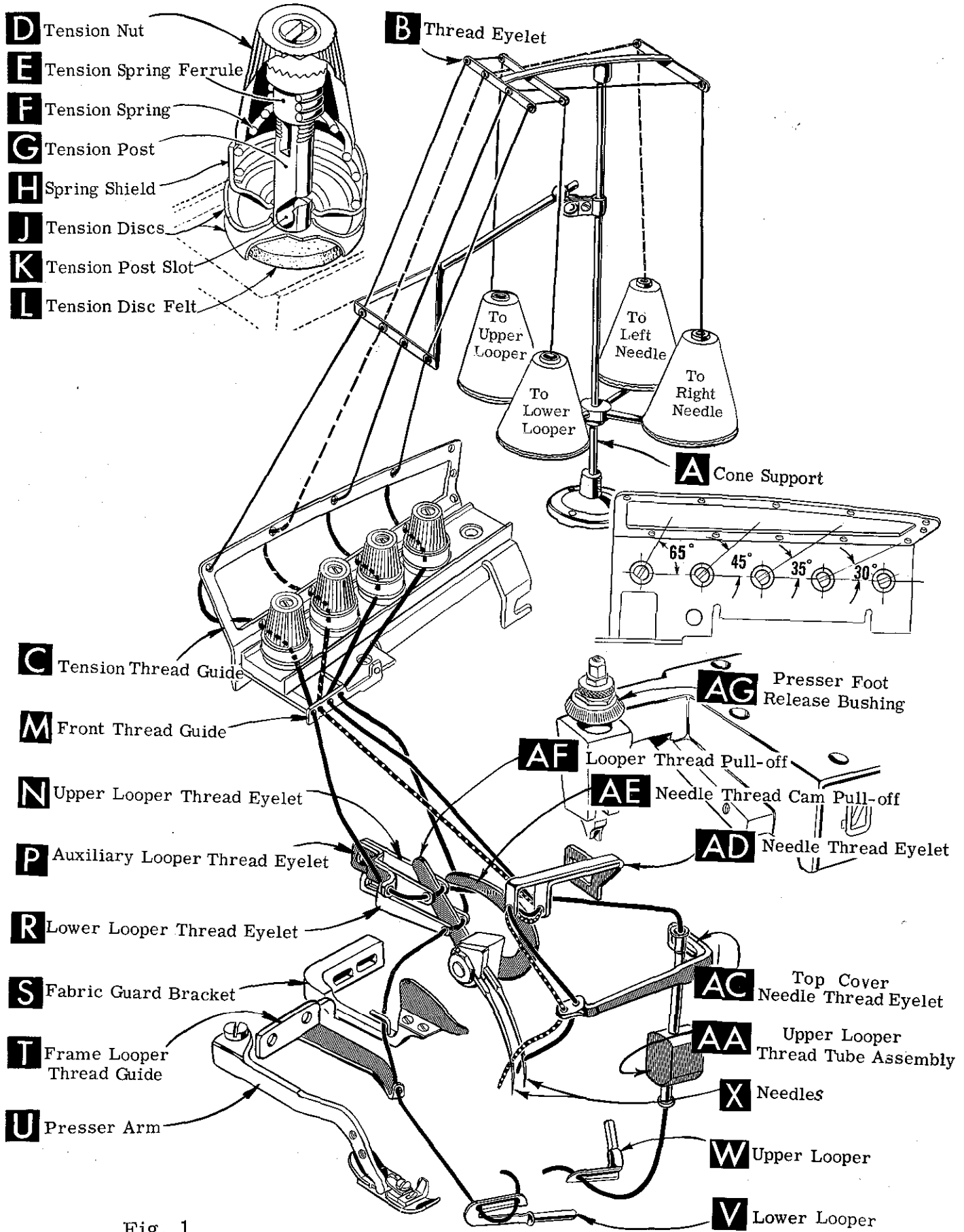

Fig. 1

CHANGING NEEDLES

Release pressure on presser foot by turning presser foot release bushing (AG, Fig. 1) and swing presser arm (U) out of position. Turn handwheel in operating direction until needles are at their lowest point of travel. Using hexagonal socket wrench No. 21388 AU, furnished with machine, loosen needle clamp nut about 1/4 turn. Again turn handwheel until needles are at high position. Withdraw needles.

To replace needles, leave needle holder at high position and with the flats to the left, insert needles in holder until they rest against stop pin. Keeping needles in this position, turn handwheel until holder is again at its low point of travel; then tighten nut. Return presser arm (U) to position; re-lock presser foot release bushing (AG).

THREAD STAND

After thread comes from cones on cone support (A, Fig. 1), the needle threads are threaded through the back bar of the thread eyelet (B), under the middle bar and through the center holes of the front bar. The looper threads come from the cones, through holes of the middle bar from back to front and then through the two outside holes of the front bar. Next it is threaded through the upper holes of tension thread guide (C) front to back and then through the lower holes from back to front. The threads continue between the tension discs (J), through tension post slot (K) in tension post (G) and on through front thread guide (M).

THREADING

Only parts involved in threading are shown in the threading diagram (Fig. 1). Parts are placed in their relative positions for clarity.

It will simplify the threading of these machines to follow the recommended sequence of threading lower looper first, upper looper second, and needles third.

Before beginning to thread, swing cloth plate open, turn handwheel in operating direction until needles (X) are in high position, release pressure on presser foot by turning presser foot release bushing (AG), and swing presser arm (U) out of position.

Be sure threads, as they come from the tension thread guide (C) are between tension discs (J) and in diagonal slots (K) in tension posts (G). The tension posts should be positioned so the tension post slot will be at the approximate angle for the different threads as indicated in Fig. 1.

TO THREAD LOWER LOOPER

Double end of thread and lead it through both eyes of lower looper thread eyelet (R, Fig. 1) from right to left. NOTE: Thread must pass in front of looper thread pull-off (AF). Lead thread behind fabric guard (S) and through eyelet hole of frame looper thread guide (T). Turn handwheel in operating direction until heel of lower looper (V) is all the way to the left; then thread through both eyes from left to right. Left eye of lower looper can be threaded easily if tweezers are in left hand.

TO THREAD UPPER LOOPER

Turn handwheel until point of upper looper (W) is all the way left. Lead thread through auxiliary looper thread eyelet (P) from back to front, then through both eyes of upper looper thread eyelet (N) from left to right. NOTE: Thread must pass in front of looper thread pull-off (AF). After pulling up upper looper thread tube assembly (AA), lead thread under neck of top cover casting and down through thread

TO THREAD UPPER LOOPER (Continued)

tube assembly (AA). Pull thread out bottom of tube; push tube down, then insert thread through upper looper eye from front to back.

CAUTION! Be sure upper looper thread is under lower looper thread when passing from tube assembly to upper looper eye.

TO THREAD NEEDLES

Turn handwheel in operating direction until needles (X) are at their highest position. Insert both needle threads from right to left, through BOTH eyes of needle thread eyelet (AD), under neck of top cover casting and down through holes in top cover needle thread eyelet (AC). The right needle thread should be threaded in the right hole and the left needle thread through the left hole of the top cover needle thread eyelet. Thread needles from the front.

THREAD TENSION

The amount of tension on needle and looper threads is regulated by tension nuts (D, Fig. 1). Tension on threads should be only enough to secure proper stitch formation.

PRESSER FOOT PRESSURE

Sufficient presser foot pressure to feed work uniformly should be maintained. Should it be necessary to increase or decrease amount of pressure on presser foot, loosen lock nut (A, Fig. 2) and turn adjusting screw (B). Adjusting screw has a right handthread so tightening increases pressure, loosening decreases pressure. When pressure adjusting screw (B) has been properly set, tighten lock nut (A). With presser foot resting on throat plate, position locking nut (C) so that its under surface is approximately 1/32 inch to 1/16 inch from the top surface of adjusting screw (B). Set cap (D) against locking nut (C).

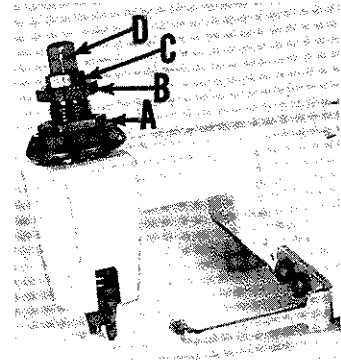

Fig. 2

FEED ECCENTRICS

Feed eccentrics used in machine Style 39500 MK have been selected to produce approximately 12 stitches per inch. It will be noted that the part number of the main feed eccentric is No. 39540 B-12, while the part number of the differential feed eccentric is No. 39540 B-4. Minor numbers of the part symbol indicate approximately the number of stitches obtainable when using that eccentric. Unless otherwise specified, machines will be shipped with the above combination of eccentrics.

Generally speaking, the main (right hand) feed eccentric determines the number of stitches produced; the differential (left hand) feed eccentric is selected so as to give the proper differential.

Following stitch number feed eccentrics are available under No. 39540 B-4, -5, -6, -7, -8, -9, -10, -11, -12, -13, -14, -15, -16, -18, -20, -22, -24, -26, -28, -30, -32, -34, -36, -40, -50, -60, -70, -100. Only two eccentrics are supplied with each machine. Additional eccentrics may be ordered separately. To order, use No. 39540 B with a minor number suffixed to indicate number of stitches desired. Example: "39540 B-12".

ASSEMBLING AND ADJUSTING SEWING PARTS

Before assembling and adjusting sewing parts, remove cloth plate, fabric guard, chip guard, upper knife assembly, lower knife holder assembly. Then, follow this suggested sequence:

CLOTH PLATE REMOVAL AND ASSEMBLY

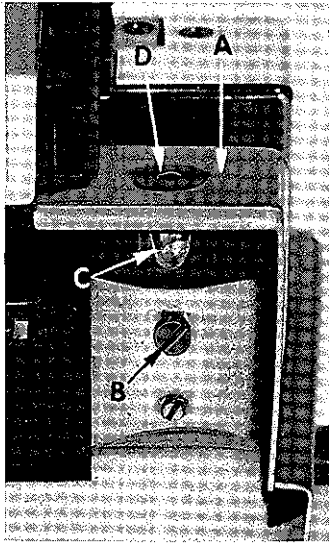

Fig. 3

CAUTION: When removing the cloth plate (A, Fig. 3) loosen the cloth plate stud locking screw (B) and lift up cloth plate with the cloth plate stud (C) and cloth plate screw (D), assembled.

In assembly, the cloth plate screw and the cloth plate stud are tightened to the point of removing all play and yet turn in cloth plate. The cloth plate is then assembled to the machine with the flat and "V" slot of the cloth plate stud (C) towards the rear. Stud locking screw (B) is tightened securely which collapses the body of the stud to the screw (D) so that only the cloth plate will turn when opening or closing.

SETTING THE NEEDLE

With throat plate assembled in position, needles should center in the front end of needle slots. When needles are at high position, needle points should be set $31/64$ inch above throat plate (Fig. 4). To align or set the height above the throat plate, move needle driving arm (A, Fig. 4) by loosening clamp screw (B). Remove throat plate, after needle has been set properly and clamp screw (B) has been tightened.

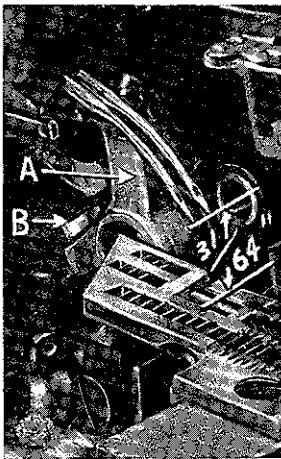

Fig. 4

If needle thread cam pull-off (A, Fig. 5) overlaps looper thread pull-off (B), separate by moving looper thread pull-off to the back. When re-tightening looper pull-off screw, be sure to take up end play in needle driving arm.

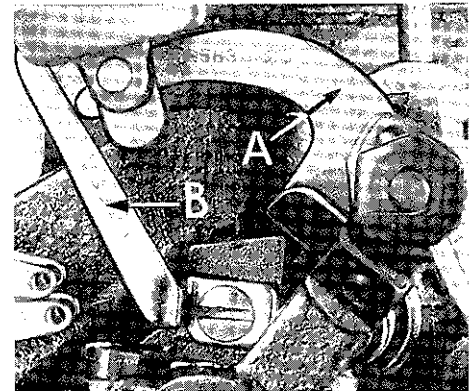

Fig. 5

At this point, insert lower looper (A, Fig. 6) into bar (B). With the lower looper at the left end of its stroke, set looper point $1/16$ inch from center of left needle (Fig. 6), using looper gauge No. 21225-1/16. Do not have lower looper deflecting needle. Tighten nut (C).

Now assemble differential (front) feed dog.

SETTING THE REAR NEEDLE GUARD

Set rear needle guard (A, Fig. 7) as high as possible, without interfering with either lower looper or movement of lower knife holder, but still in position to deflect needles forward .002-.004 inch. Screw (B) is used to set rear needle guard. Make sure there is no interference between rear needle guard and lower looper.

SETTING THE LOWER LOOPER

Now, finish lower looper adjustment. As lower looper moves to the right, its point should be set into the scarf of the left needle (A, Fig. 8) until the needles spring forward from rear guard surface another .002-.004 inch.

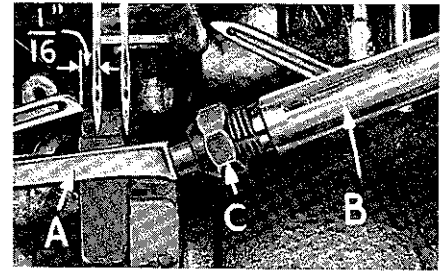

Fig. 6

SETTING THE FRONT NEEDLE GUARD

Assemble front needle guard (C, Fig. 7). When lower looper is springing needles off rear needle guard, set front needle guard as close as possible to needles without touching. Screw (D) is used to adjust and set front needle guard. After this setting, make sure there is no interference between needle guards and differential feed dog.

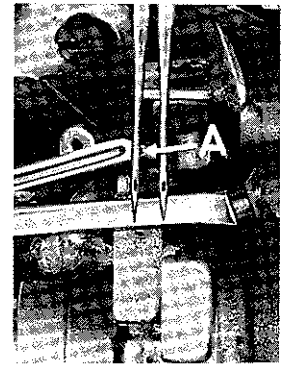

Fig. 8

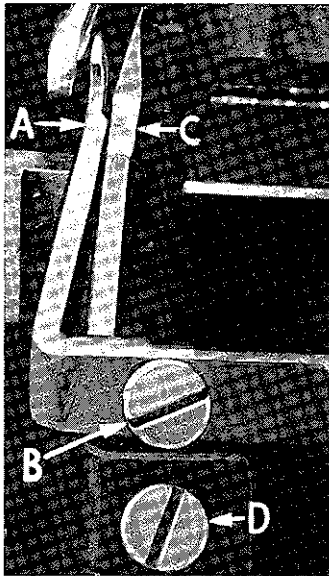

Fig. 7

SETTING THE UPPER LOOPER

Insert upper looper (A, Fig. 9) in its holder. Screw (B) holds upper looper in its holder, and permits it to be pushed in or out or turned around its shank. Insert upper looper holder into upper looper shaft, if it is not already in place. Screw (C) on clamp holds the upper looper holder in the shaft. Locate upper looper in its holder so that the shank extends $\frac{1}{8}$ inch beyond holder.

When the upper looper is at the right end of its stroke, upper looper holder should be set to position upper looper shank slightly back of vertical (Fig. 9).

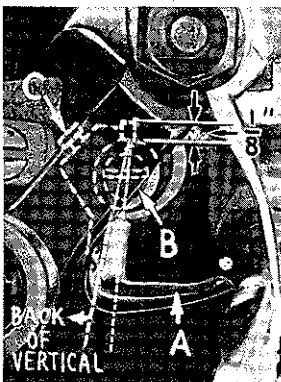

Fig. 9

By adjusting looper holder in or out of upper looper shaft and by turning the looper around its shank, set upper looper point to cross lower looper to the left of the lower looper eye with .002 to .004 clearance (Fig. 10).

Next, turn the handwheel until upper looper is at the left end of its travel. Check dimensions of upper looper point with respect to the left needle and throat plate (Fig. 11). If resetting is necessary, do it by moving the upper looper holder (A, Fig. 11). Figure 11 represents the correct dimensional setting.

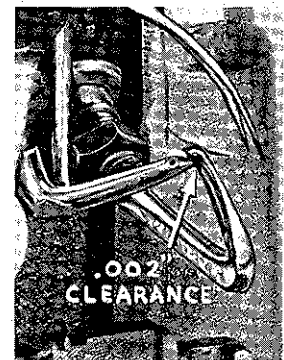

Fig. 10

SETTING THE UPPER LOOPER (Continued)

Dimension $39/64$ inch is increased by turning upper looper holder counterclockwise looking from left end of machine. Dimension $3/16$ inch is increased by pulling upper looper holder to the left, out of the upper looper shaft. After these changes are made, it may be necessary to turn the upper looper around its shank slightly to maintain the condition shown in Fig. 10.

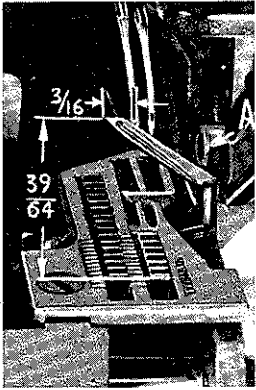

Fig. 11

Check setting to avoid interference between upper looper and needle on needle downstroke. If needle rubs the back of upper looper, pull looper out of its holder slightly and rotate looper a short distance counterclockwise, looking from left end of machine. Reset to maintain dimensions of Figs. 10 and 11.

SETTING THE FEED DOGS

Assemble the main and differential feed dogs (A, B, Fig. 12). Main and differential feed dogs should be leveled with respect to the throat plate by rotating feed tilting adjusting pin (C). This pin raises or lowers the back end of the feed bar.

The feed dogs should be set level at the time the teeth first appear above the throat plate. Screw (D) locks feed tilting adjusting pin in place. With the feed dogs at their highest point of travel, the top of the teeth on the main and differential feed dogs (A, B) should be the depth of a full tooth above the throat plate. The chaining feed dog is made as an integral part of the main feed dog.

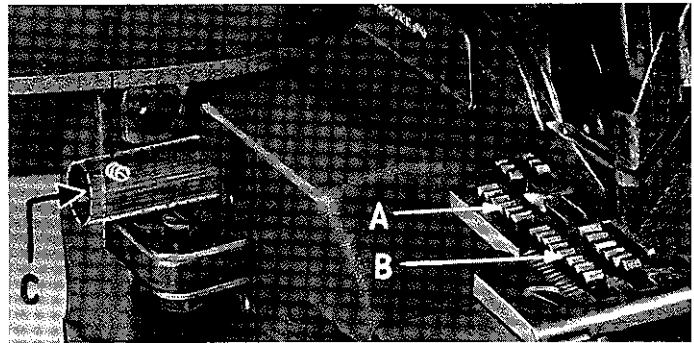

Fig. 12

SETTING THE LOWER KNIFE

Replace lower knife holder assembly. Lower knife (A, Fig. 13) should be set with cutting edge flush with throat plate surface. Adjustments are made with hexagonal head screw which holds lower knife. Lower knife is spring pressed against upper knife, so no lateral adjustment is necessary when width of trim is changed.

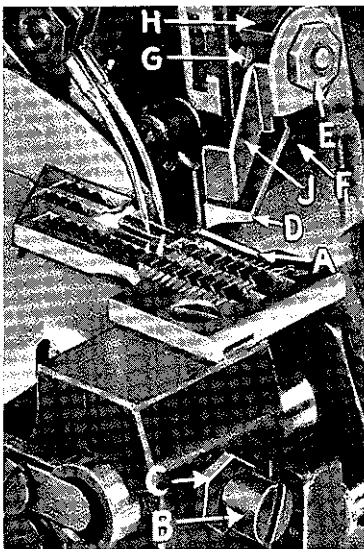

Fig. 13

Lower knife may be secured in any position by tightening screw (B) and locking nut (C) against support bracket. Because screw (B) also serves as latch pin for the cloth plate latch spring, it should always be locked with nut (C) even when screw is not tightened against lower knife holder.

SETTING THE UPPER KNIFE

Replace upper knife assembly. Clamp upper knife (D, Fig. 13) in position, setting nut (E) to hold clamp (F) in its most clockwise position against upper knife. Upper knife chain guard (J) should be positioned so that the guarding section is approximately $1/64$ inch behind the cutting edge and in contact with the top surface of the upper knife.

SETTING THE UPPER KNIFE (Continued)

At the bottom of its stroke, front cutting edge of upper knife should extend not less than $1/64$ inch below cutting edge of lower knife.

After upper knife has been set for the proper width of trim, screw (G) must be tightened to lock the upper knife holding block (H) in place. This will simplify resetting when upper knife is replaced.

SETTING THE STITCH LENGTH

Length of stitch is determined by the combination of feed eccentrics used. Outer (left) eccentric (A, Fig. 14) actuates differential (front) feed dog; while the inner (right) eccentric (B) actuates the main (rear) feed dog.

In assembling feed eccentrics, be sure hubs are facing each other. Be careful not to damage shaft or key. Use nut (C) and washer (D) and tighten securely.

To change feed eccentric, remove thrust finger (L) from its seat on the main frame (M). Remove nut (C) and washer (D) from end of shaft (G). Remove nut (H) from stud (J). Link (K) and eccentric (A) will now slip off.

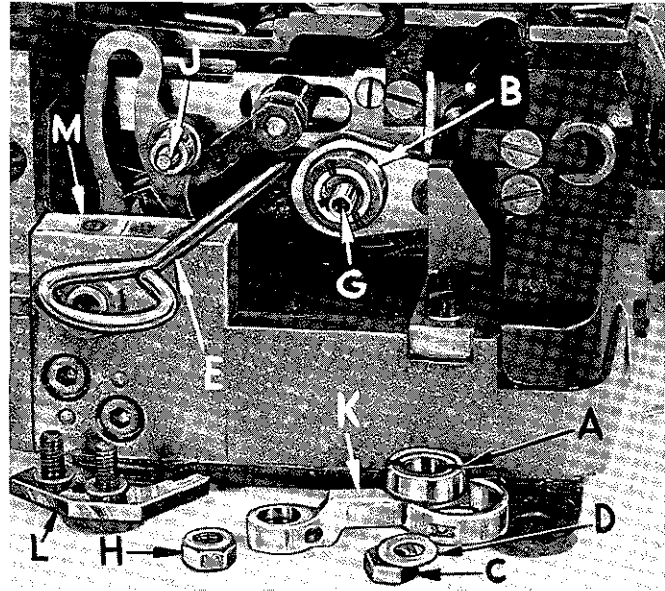

Fig. 14

Using hooked eccentric extractor (E), supplied with machine, reach behind eccentric (B) as shown and withdraw eccentric. It may be necessary to move handwheel back and forth slightly during extraction.

SETTING THE DIFFERENTIAL RATIO

Differential feed action is obtainable thru the use of a micrometer adjusting screw (A, Fig. 15).

The position of the differential control lever (B, Fig. 15) is governed by an upper stop (C) and a lower stop (D). The amount of lever movement between these two stops determines the feed action.

Rotating the adjusting thumbscrew in a clockwise direction increases the differential action by moving the the upper stop (C) down, a counterclockwise turn acts in a reverse manner. Now set the lower stop screw (D) so as to obtain the required differential feed. The two stops may be reversed to meet a specific sewing requirement.

NOTE: After lower stop screw has been set, push differential control lever down, hold in this position and turn handwheel in operating direction to be sure the differential feed dog does not strike the throat plate.

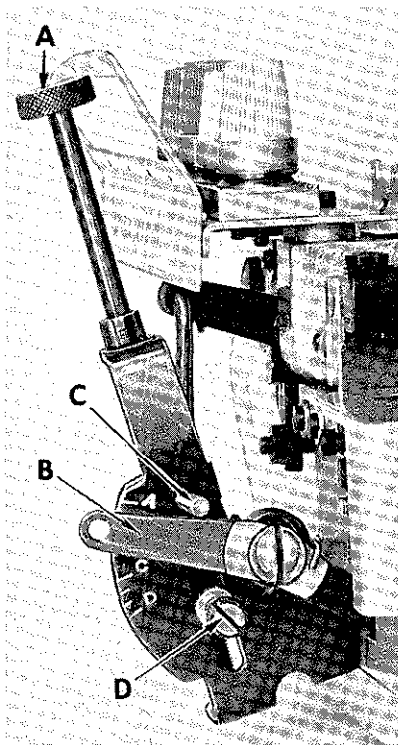

Fig. 15

SETTING THE PRESSER FOOT

Assemble the presser foot to presser arm. With needle in high position, swing presser arm into sewing position and set the presser foot to align needle holes (front and back) and flat on throat plate. The front edge of needle hole in presser foot must be aligned with front edge of needle holes in throat plate.

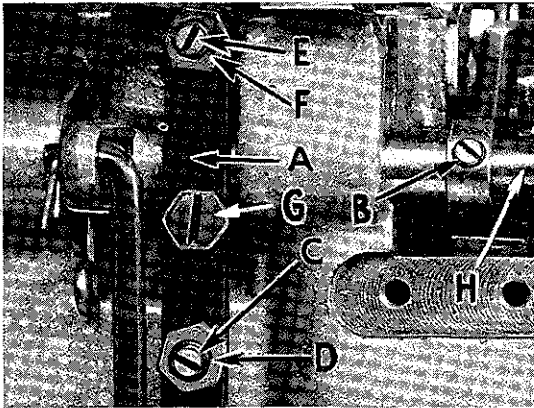

Fig. 16

It is also important that the bottom of the presser foot be flat on the throat plate. If necessary, presser foot can be realigned with throat plate slots by shifting the foot lifter lever shaft (H, Fig. 16). To move the shaft, loosen collar screws (B, Fig. 16) and clamp screw (G) and then shift the foot lifter lever shaft to the left or right as required. Retighten collar screws and clamp screw.

The foot lifter lever arm (A, Fig. 16) and the collar (B) secure the shaft. Be sure the presser arm does not bind and rise when presser foot release bushing is unlocked.

Adjust lifter lever stop screw (C) so that presser foot can be raised no higher than upper looper will permit; then lock the nut (D). There should be from $1/16$ to $1/8$ inch free motion of foot lifter lever before the presser foot begins to rise. This adjustment should be made with screw (E) and locked with nut (F). Re-assemble the chip guard, fabric guard and cloth plate. To make assembly of chip guard easy, turn handwheel until upper knife assembly reaches its highest position.

SETTING THE PRESSER FOOT HOLD DOWN PLATE

This machine is equipped with a presser foot hold down plate (A, Fig. 17). The purpose of this plate is to hold down the rear of the presser foot and when set correctly it will help produce a more flat pucker free seam. An approximate setting is shown in Fig. 17. Set the machine with the feed dogs below the throat plate and insert a .005 inch shim (B) under the front portion of presser foot (C). Loosen screws (D) which hold the hold down plate in position and move the plate down until it rests firmly against the presser foot. Tighten the two screws and remove the shim.

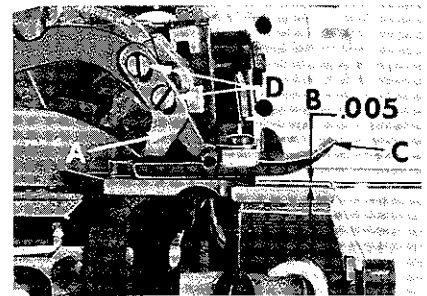

Fig. 17

NOTE: Always be sure the feed dogs are below surface of throat plate when making this setting.

STARTING TO OPERATE

Be sure machine is threaded according to threading diagram (Fig. 1). With thread tensions light, set looper thread eyelets (N & R) about horizontal and in the middle of their front to back locations. Operate machine slowly, without presser foot in place, to make sure that chain forms and moves off the tongue freely. Swing presser foot into position, insert material, and sew slowly.

NEEDLE THREAD CONTROL

While sewing on material, check needle thread control as follows: Usually all needle thread is drawn on needle down stroke. At top of needle stroke, thread should be just tight enough to feed chain off stitch tongue. Stitch tends to pull down slightly if excessive thread is pulled on the up stroke. With needle at bottom of stroke, position needle thread eyelet (AD, Fig. 1) so that needle cam pull-off (AE) just contacts needle thread.

LOWER LOOPER THREAD CONTROL

With material under presser foot, set lower looper thread eyelet (R, Fig. 1) back far enough so thread is a little slack when looper thread pull-off (AF) reaches its most rearward position. Looper thread pull-off (AF) is set about 1/8 inch distance behind needle thread cam pull-off (AE). Frame looper thread guide (T) should be set with its eyelet approximately 1/8 inch to the right of lower looper (V) heel eyelet at the time lower looper is at extreme left end of its travel.

While sewing on material, check drawing off of looper thread as follows: A portion of lower looper thread should be drawn through the tension before lower looper thread comes off upper looper. To increase amount of thread drawn through the tension while lower looper thread is on upper looper, move lower looper thread eyelet (R) down, keeping the same amount of pull-off action.

UPPER LOOPER THREAD CONTROL

Before proceeding to adjust upper looper thread eyelet (N, Fig. 1) balance all four tensions to give a normal appearing stitch. Moderate change in these tensions will not markedly affect the purl.

During needle down stroke, forward stroke of looper thread pull-off (AF) will draw upper thread through the tension. When normal amount of looper thread is drawn, upper looper thread will have almost all slack taken up as looper thread pull-off reaches its most rearward position.

POSITIONING THE PURL

To move the purl more under the edge, both looper thread eyelets (N and R, Fig. 1) should be raised keeping the same amount of pull-off. Usually, it is better to have slightly more pull-off on upper thread than on lower thread.

If it becomes necessary to move looper thread pull-off (AF), be sure to take up all end play in needle drive shaft before tightening. If upper looper is located so that it is higher over throat plate than recommended in (Fig. 11), the purl will tend to form near top edge. If upper looper is too low, the purl will form nearer bottom edge.

THREAD TENSIONS

The needle thread tension required is a function of needle thread and material being sewn. In general, lower looper thread tension should be set as high as possible without causing needle thread to be pulled down. Upper looper thread tension should be increased as long as the elasticity of the chain increases, or until the purl is pulled too far over the top. Keep tensions as light as possible and use eyelets and take-ups to get the proper stitch.

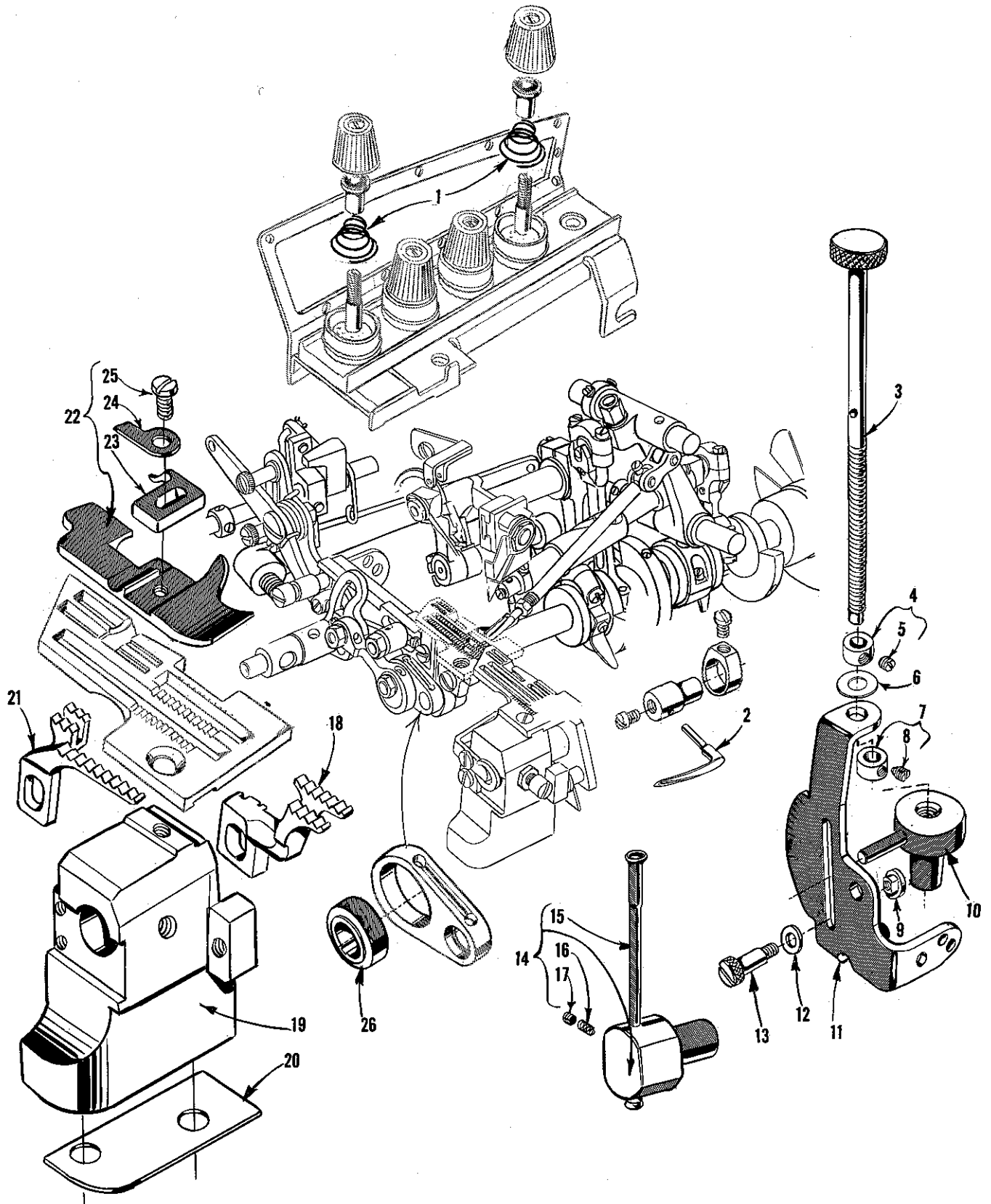

The parts illustrated on the preceding page and described below represent the parts that are used on Style 39500 MK, but not used on Style 39500 GD.

Those parts shown in phantom views and bearing no reference numbers are common to Styles 39500 GD and MK.

Use Catalog No. 103 FS (Style 39500 GD) for all parts not illustrated or described in this catalog.

Reference numbers that are inside a bracket on the picture plate and have indented descriptions indicate they are component parts of a complete part or assembly.

<u>Ref. No.</u>	<u>Part No.</u>	<u>Description</u>	<u>Amt. Req.</u>
1	39592 AR-5	Upper and Lower Looper Thread Tension Spring -----	2
2	39508 C	Upper Looper, marked "CJ" -----	1
3	39536 AB	Differential Feed Control Adjusting Rod -----	1
4	161	Adjusting Rod Stop Collar, upper -----	1
5	88	Screw -----	1
6	39536 AD	Spring Washer -----	1
7	161 A	Adjusting Rod Stop Collar, lower -----	1
8	22764	Screw -----	1
9	43139 A	Nut, for stop screw -----	1
10	39536 AC	Differential Feed Control Adjustable Stop -----	1
11	39536 AJ	Differential Feed Control Mounting Bracket -----	1
12	8372 A	Washer, for stop screw -----	1
13	22728 A	Differential Feed Stop Screw -----	1
14	29477 HJ	Upper Looper Thread Tube Assembly -----	1
15	39568 P	Thread Tube -----	1
16	39568 J	Thread Tube Tension Spring -----	1
17	22743	Screw, for thread tube tension spring -----	1
18	39526 AT	Differential Feed Dog, marked "FF", 12 t.p.i. -----	1
19	39580 AE	Throat Plate and Lower Knife Support Bracket -----	1
20	39580 E	Shim, for support bracket -----	1
21	39505 AT	Main Feed Dog, marked "FE", 12 t.p.i. -----	1
22	39520 W	Presser Foot -----	1
23	39597 W	Stitch Tongue, marked "EF" -----	1
24	39530	Hinge Spring -----	1
25	22768 B	Screw -----	1
26	39540 B-12	Main Feed Driving Eccentric -----	1



Union Special[®]
INDUSTRIAL SEWING MACHINES

UNION SPECIAL maintains sales and service facilities throughout the world. These offices will aid you in the selection of the right sewing equipment for your particular operation. Union Special representatives and service men are factory trained and are able to serve your needs promptly and efficiently. Whatever your location, there is a Union Special Representative to serve you. Check with him today.

ATLANTA, GA.

BOSTON, MASS.

CHICAGO, ILL.

DALLAS, TEXAS

LOS ANGELES, CAL.

NEW YORK, N. Y.

PHILADELPHIA, PA.

MONTREAL, CANADA

TORONTO, CANADA

BRUSSELS, BELGIUM

LEICESTER, ENGLAND

LONDON, ENGLAND

PARIS, FRANCE

STUTT GART, GERMANY

Representatives and distributors in all important industrial cities throughout the world.

Union Special

MACHINE COMPANY

400 N. FRANKLIN ST., CHICAGO, ILL. 60610